



## RAY PULL

The perfect mix of form and function with the stepped cut-out gives the pull a beautiful visual pattern whilst acting as grip for the user. The brass is left raw and will patina overtime telling the story of how it has been used.

This pull is part of the collection named after one of our most experienced and remembered machinist to grace our factory floors. Ray worked tirelessly for us during the 80's and 90's and while he had many talents, one of his best was his ability to talk about his talents. This range is designed to do just that, tell a story of its manufacturing process.

The material is left raw with its 'skin on' showing its imperfections of being heated up and extruded. All the machining lines are left visible so you can see the story of where the tools have passed over the product resulting in the unique pattern that usually gets hidden by post polishing. We believe our machining is worth talking about and this product does just that..

**MATERIAL**

Solid Brass\*

\* Living finish

**DIMENSIONS**

**WEIGHTS**

140g approx.

**SUPPLIED**

1 x Pull / 2 x Screw (M4 x 25mm csk stainless steel)

Rear Fixing.

Screws provided suit doors / drawers 16mm - 18mm Thick.

**INSTALLATION**

Door or drawer - ø6mm hole.

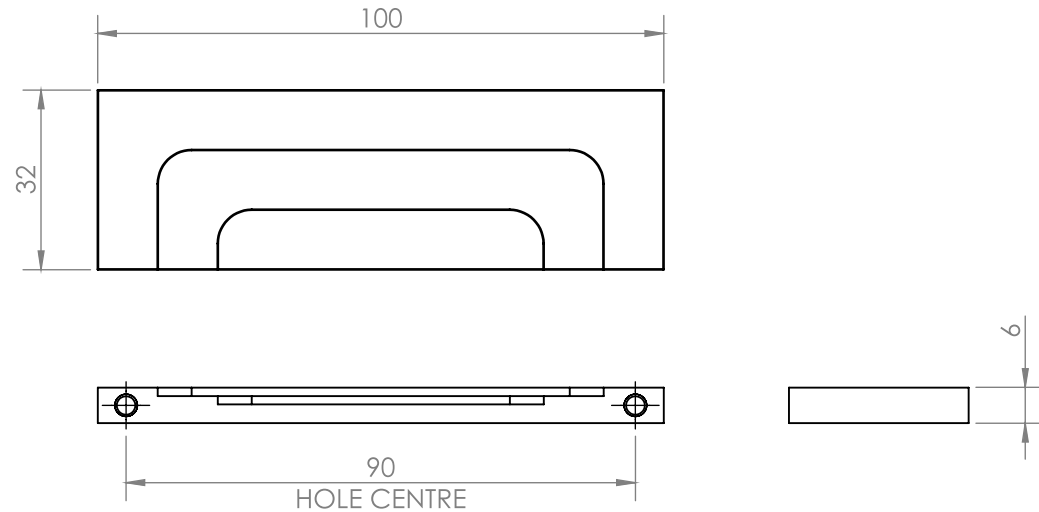

**CARE INSTRUCTION**

Dust with a clean micro fiber cloth. Wipe down with a damp micro fiber cloth.

Do not use abrasives. Do not use harsh chemicals. Warm mild soapy water can be used on stubborn dirt.

Dry surface after cleaning with a clean cloth.

**LIVING FINISHES**

This product is made from raw material and will patina over time and with use. To find out more visit:

[savagedesign.com.au/portfolio/living\\_finishes/](http://savagedesign.com.au/portfolio/living_finishes/)