

S VAGE DESIGN

MADDOX TWIN SHELF - PRODUCT PROFILE

ENGINEERED BEAUTY
SINCE 1910 / SYD - AUS



WELCOME TO MADDOX

Savage Design introduces the Maddox Twin Shelf, the most pared back collection of Maddox components possible to create a plug and play storage solution for the kitchen, bar, laundry, garage or office. The Maddox System epitomises Savage Design's dedication to **Engineered Beauty**. The Maddox Twin Shelf is a certified carbon neutral product.



Follow these 2 steps to choose your Twin Shelf

1 STYLE - Choose your style

TWIN SHELF

Wall mounted frame in your choice of finish.

x2 Black powdercoated aluminium shelves.

600 WIDE

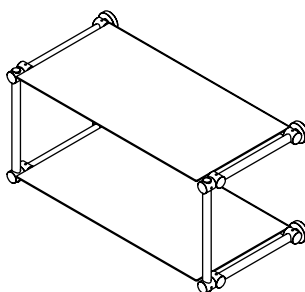

900 WIDE

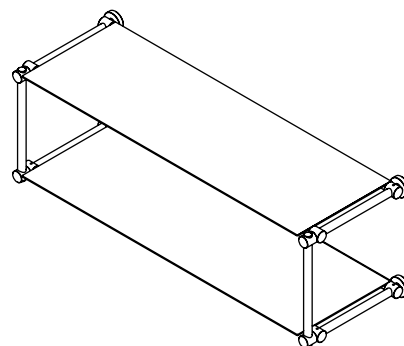

TWIN SHELF PLUS

Wall mounted frame in your choice of finish.

x2 Black powdercoated aluminium shelves.

x2 Shelf fence

x1 Bottom rail

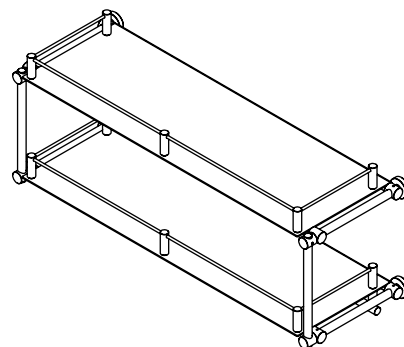
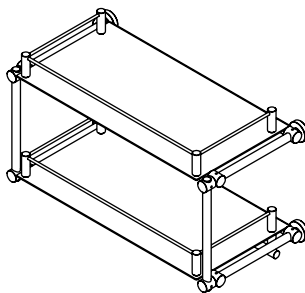

2 FINISHES - Frame

FRAME

Choose from our four signature finishes*



Brass

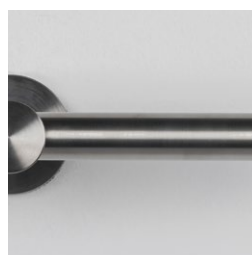

Stainless Steel

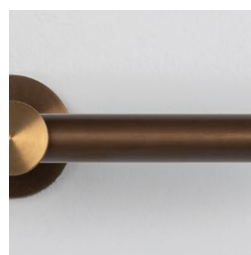

Aged Bronze

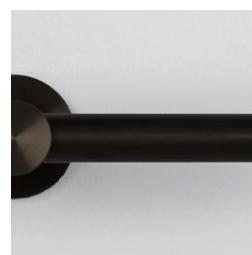

Blackened Brass

* Our metals are all living finishes. Find out more here - savagedesign.com.au/portfolio/living_finishes/

DIMENSIONS

TWIN SHELF

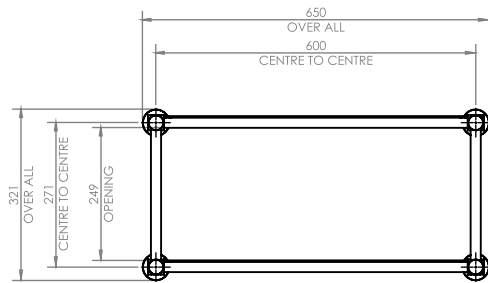

14kg

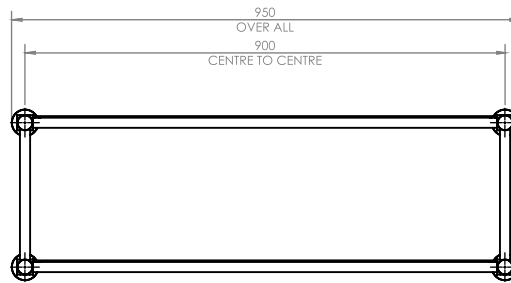

19kg

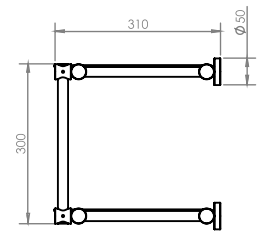

Maddox Twin Shelf
900mm in Aged Bronze
pictured.



TWIN SHELF PLUS

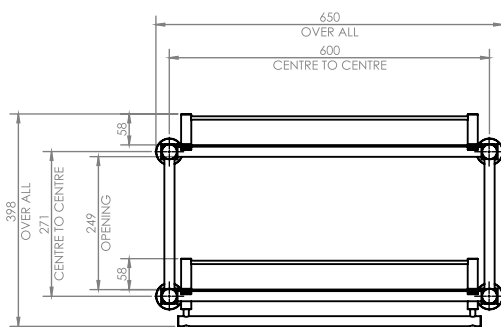

18kg

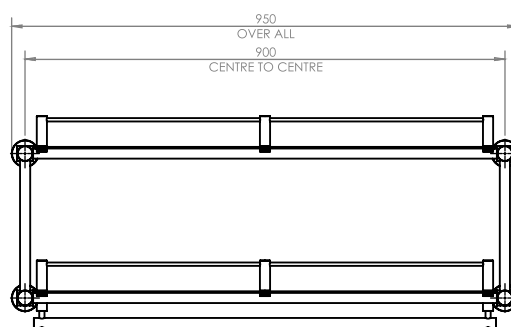

23kg

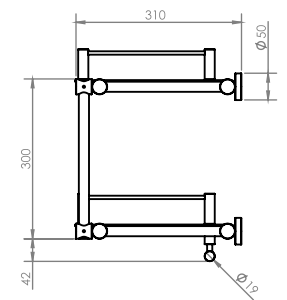

Maddox Twin Shelf Plus
900mm in Aged Bronze
pictured.



RECOMMENDATIONS

When fitting Maddox into alcoves, nooks or between surfaces, please ensure the minimum clearance as shown here.

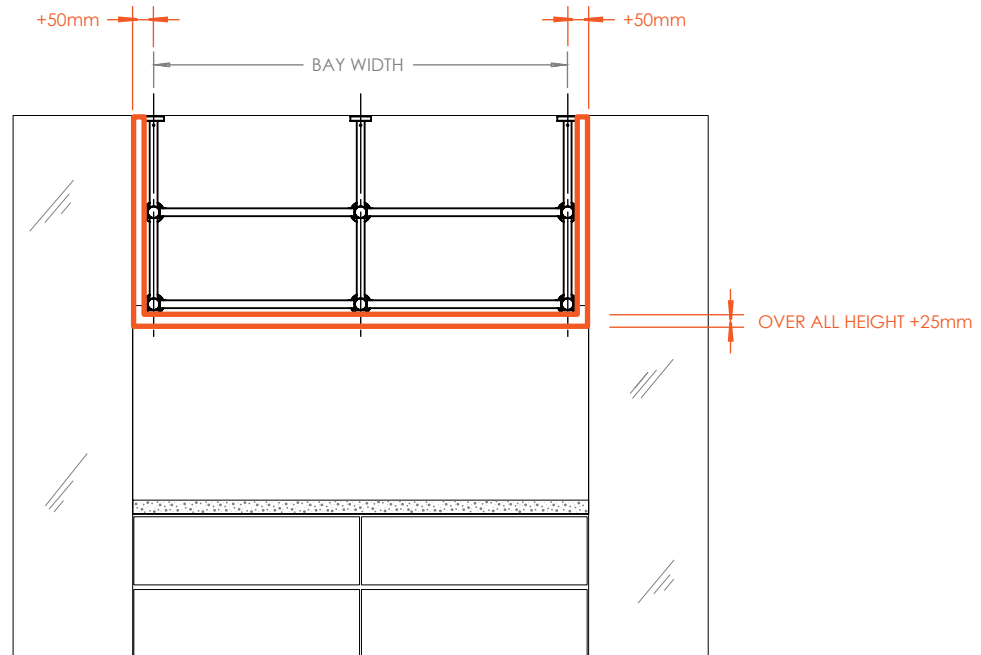

Maddox Bush Flange load rating and fixings.

The Maddox Bush Flange is screw fixed to its position. Screws provided are 8G x 20mm to suit most applications.

Longer screws, wall plugs or wall anchors may be needed at installers discretion.

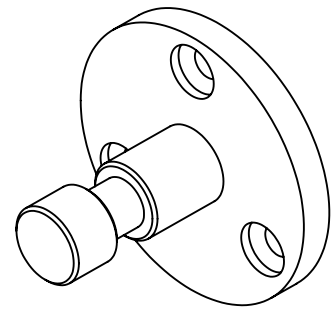

50kg load per Bush Flange

Always supplied in Brass

Maddox mounting surfaces.

Whatever Maddox is fixed to, it must have sufficient structure to take the weight of the Maddox unit and items being placed on it.

Suitable surfaces may include Timber, Ply or Engineered Timbers, Masonry and Concrete.

CAUTIONS

Plasterboard – Requires sufficient timber battens or timber paneling

Tile – Maddox can be fitted to tiles. There needs to be sufficient rigid structure behind the tiled surface for it to be fixed to.

Maddox can not be fixed directly to glass or mirror.



SHOWROOM - Surry Hills
FACTORY - Fairfield
New South Wales, Australia

hello@savagedesign.com.au



S V A G E DESIGN

ENGINEERED BEAUTY
SINCE 1910 / SYD - AUS