

Ray Collection





## Ray Collection

This range is named after one of our most experienced and remembered machinist to grace our factory floors. Ray worked tirelessly for us during the 80's and 90's and while he had many talents, one of his best was his ability to talk about his talents. This range is designed to do just that, tell a story of its manufacturing process.

The material is left raw with its 'skin on' showing its imperfections of being heated up and extruded. All the machining lines are left visible so you can see the story of where the tools have passed over the product resulting in the unique pattern that usually gets hidden by post polishing. We believe our machining is worth talking about and this product does just that.

The collection consists of The Ray Coaster - raw, simple, stackable and beautiful, The Ray Tray - A statement piece on its own This tray is perfect table object for the office or at home, The Ray Pen - Encompassing so much of our design ethos with simple form and refined details that allows the material to be the hero, The Ray Soap Dish - An almost forgotten commodity of the bathroom, but Ray is here to change that, and The Ray Pull - A perfect mixture of form and function.



## Ray Coaster

### Material

Solid Brass (Raw)

### Weight

375 g each

### Dimensions

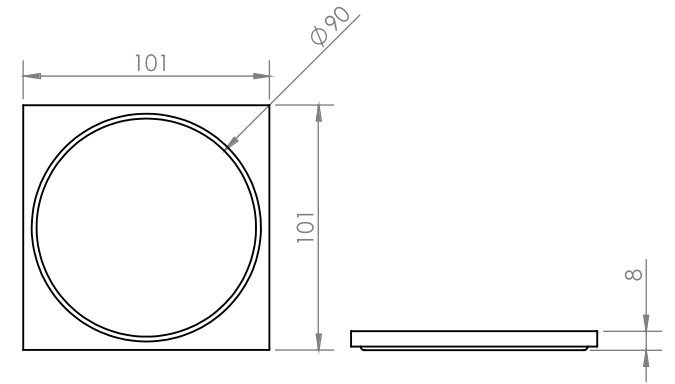

Its raw, simple and beautiful. One can be used as a statement, holding your favourite whiskey glass or stack a number of them on your table and let your guests get involved. The O-ring on the bottom of the coaster means only rubber touches your table and helps locate your coaster into place when you stack them on top of one another.

### Care instruction

Wipe down with a damp cloth. Don't not use abrasives and avoid chemicals. Warm mild soapy water can be used on stubborn dirt. Dry surface after cleaning with a clean cloth.

### Raw materials

This product is made from raw material and is a living finish. it will patina over time and with use.



# Ray Soap Dish

## Material

Solid Brass (Raw)

## Weight

510 g each

## Dimensions

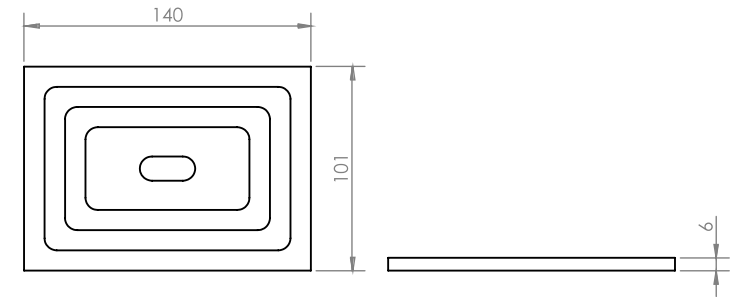

The soap dish is an almost forgotten commodity of the bathroom. But Ray is here to change that. The stepped profile allows air to circulate around your soap allowing it to last longer while also creating a beautiful shape to the dish. The O-ring on the underside not only protects your sink but also prevents soap scum from running everywhere.

## Care instruction

Wipe down with a damp cloth. Don't use abrasives and avoid chemicals. Warm mild soapy water can be used on stubborn dirt. Dry surface after cleaning with a clean cloth.

## Raw materials

This product is made from raw material and is a living finish. It will patina over time and with use.



## Ray Tray

### Material

Solid Brass (Raw)

### Weight

980 g each

### Dimensions

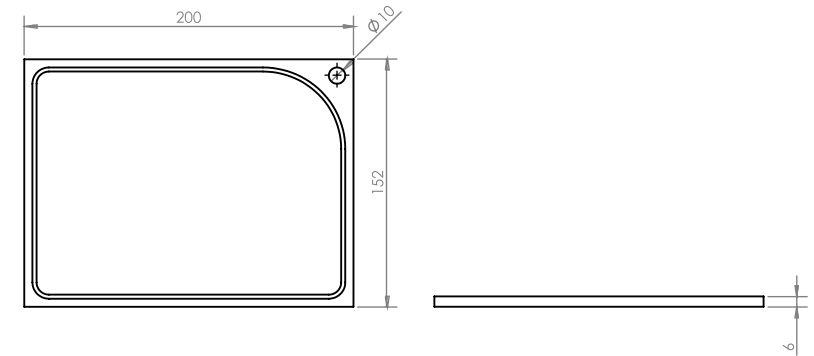

This is the type of tray you will not want to put anything in. A statement piece on its own the pattern generated is from the toolpath of the machine when the material is being removed. There is also a machined hole in the corner that perfectly holds our Ray Pen (sold separately). This tray is perfect table object for the office or at home.

### Care instruction

Wipe down with a damp cloth. Don't not use abrasives and avoid chemicals. Warm mild soapy water can be used on stubborn dirt. Dry surface after cleaning with a clean cloth.

### Raw materials

This product is made from raw material and is a living finish. it will patina over time and with use.



## Ray Pen

### Material

Solid Brass (Raw)

### Weight

60 g each

### Dimensions

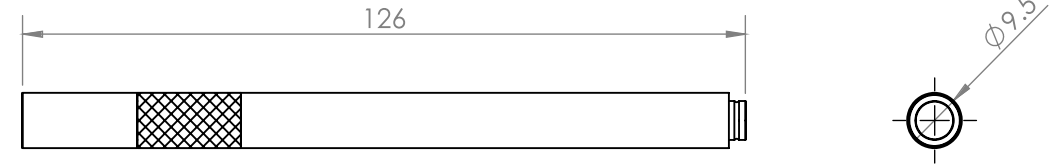

Encompasses so much of our design ethos. Simple forms with refined details that allows the material to be the hero. The pen is made up of machined componentry that screws together. It has our signature knurled detail to act as grip and the lid clips on using an O-ring. The brass is left raw and will patina beautifully overtime showing the user how it has been handled. The pen has a ceramic rollerball black ink that makes it wonderful to write with.

### Care instruction

Wipe down with a damp cloth. Don't not use abrasives and avoid chemicals. Warm mild soapy water can be used on stubborn dirt. Dry surface after cleaning with a clean cloth.

### Raw materials

This product is made from raw material and is a living finish. it wall patina over time and with use.



## Ray pull

### Material

Solid Brass (Raw)

### Weight

140 g each

### Dimensions

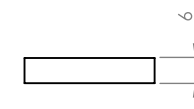
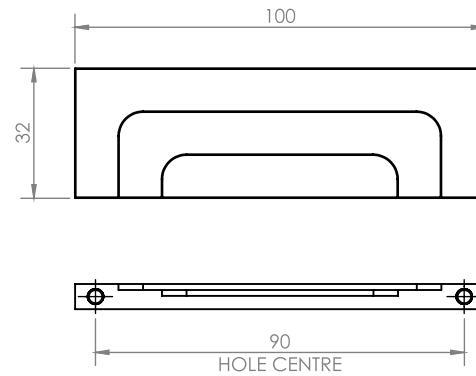

Hole size 4.5mm Dia in door

### Care instruction

Wipe down with a damp cloth. Don't not use abrasives and avoid chemicals. Warm mild soapy water can be used on stubborn dirt. Dry surface after cleaning with a clean cloth.

### Raw materials

This product is made from raw material and is a living finish. it will patina over time and with use.

